

Residential Atmospheric Vent High Performance Energy Saver Gas Water Heater



Photo is of
GX-2-25S6BN

The Atmospheric Vent High Performance Models feature:

- **High Input Combustion System**—Generates enough hot water in the first hour for hot tubs, garden tubs and body sprays in addition to whole house duty.
- **High Recovery and First Hour Delivery**—When tested to the industry standard residential first hour delivery procedure, the GX2-25S can provide 155 gallons and the GX1-55S will deliver 200 gallons.
- **Integrated Mixing Device**—Features an accurate, easy to use hand wheel for adjusting mixed water temperature, a pre-piped stainless steel flexible connector for quick installation as well as optional water connections (1/2" NPT recirculation inlet, 1/2" NPT hot water outlet, 1/4" NPT cold water outlet). This required system is easily installed and ensures a comfortable outlet temperature while providing a steady flow of hot water.
- **Helical Fin Flue**—Designed to maximize the amount of heat transferred to water decreasing recovery time. Minimizes air movement in the heater during standby periods to retard heat loss up the flue.
- **Factory Installed Hydrojet 2™ Total Performance System**—Cold water inlet sediment reducing device helps prevent sediment build up in tank. Increases first hour delivery of hot water while minimizing temperature build up in tank.
- **Vitraglas® Lining**—Bradford White water heater tanks are protected from the corrosive effects of hot water by an exclusive ceramic porcelain-like coating. The Bradford White high silica Vitraglas® lining provides a tough interior surface for our hot water tanks.
- **Fully Automatic Controls**—Automatic temperature selection at your fingertips. Built-in energy cut-off switch prevents abnormally high water temperature for extra safety. Built-in gas pressure regulation.
- **3/4" NPT Side Connections.**
- **Non-CFC Foam Insulation**—Energy saving insulation covers the sides and top of the tank, reducing the amount of heat loss while increasing jacket rigidity. GX-2 has 2" of insulation, GX-1 has 1" of insulation.
- **Water Connections**—3/4" NPT factory installed true dielectric fittings extend water heater life and eases installation.
- **Two Protective Magnesium Anode Rods**—Provide added protection against corrosion for long trouble-free service.
- **4" "Snap Lock" Draft Diverter.**
- **T&P Relief Valve**—Installed.
- **Brass Drain Valve**—Durable tamper proof design.

AUDI
ATRI



6-Year Limited Tank Warranties / 6-Year Limited Warranty on Component Parts.

For more information on warranty, please visit www.bradfordwhite.com

For products installed in USA, Canada and Puerto Rico. Some states do not allow limitations on warranties. See complete copy of the warranty included with the heater.

MANUFACTURED UNDER ONE OR MORE OF THE FOLLOWING U.S. PATENTS: 5,954,492; 5,761,379; 5,943,984; 5,081,696; 5,988,117; 6,142,216; 5,199,385; 5,574,822; 5,372,185; 5,485,879; 5,277,171; (B1)5,341,770; 5,660,165; 5,596,952; 5,682,666; 4,904,428; 5,023,031; 5,000,893; 4,669,448; 4,829,983; 4,808,356; 5,115,767; 5,092,519; 5,052,346; 4,416,222; 4,628,184; 4,861,968; 4,672,919; Re. 34,534; 7,270,087 B2. OTHER U.S. AND FOREIGN PATENT APPLICATIONS PENDING. CURRENT CANADIAN PATENTS: 1,272,914; 1,280,043; 1,289,832; 2,045,862; 2,112,515; 2,108,186; 2,107,012; 2,092,105; 2,409,271. Vitraglas® and Hydrojet® are registered trademarks of Bradford White® Corporation.

Residential Atmospheric Vent Gas Water Heater

High Performance Energy Saver Models

NATURAL GAS AND LIQUID PROPANE MODELS

Meet or exceed ASHRAE 90.1b (current standard) C.E.C. Listed
82% Thermal Efficiency

Model Number	Capacity		Nat. BTU/Hr. Input		Recovery at 90°F Rise*				A	B	C	D	E	F	G	H	J	K	Approx. Shipping Weight
	U.S. Gal.	Imp. Gal.			Nat. U.S. GPH	Nat. Imp. GPH	LP U.S. GPH	LP Imp. GPH	Floor to Flue Conn in.	Jacket Dia. in.	Vent Size in.	Floor to T&P Conn. in.	Floor to Gas Conn. in.	Floor to Space Heating Return in.	Floor to Space Heating Outlet in.	Floor to Heater Top in.	Floor to Water Conn.† in.	Depth in.	
GX-2-25S6BN	25	21	78,000	76,000	84	70	82	68	58½	18	4	50	14½/16	15½/16	50	54⅞	58⅞	22	150
GX-1-55S6BN	55	46	80,000	78,000	86	72	84	70	59⅞	22	4	50	14½/16	15½/16	50	56	60	26¼	200

Model Number	Capacity		Nat. kW Input		LP kW Input		Recovery at 50°C Rise*		A	B	C	D	E	F	G	H	J	K	Approx. Shipping Weight
	Liters				Nat. Liters/Hour	LP Liters/Hour			Floor to Flue Conn mm.	Jacket Dia. mm.	Vent Size mm.	Floor to T&P Conn. mm.	Floor to Gas Conn. mm.	Floor to Space Heating Return mm.	Floor to Space Heating Outlet mm.	Floor to Heater Top mm.	Floor to Water Conn.† mm.	Depth mm.	
GX-2-25S6BN	94		22.9	22.3	318	310			1486	457	102	1270	376	392	1270	1387	1489	559	68
GX-1-55S6BN	208		23.5	22.9	326	317			1514	559	102	1270	376	392	1270	1422	1524	667	91

Propane models feature a Titanium Stainless Steel propane burner.

For propane (LP) models, change suffix "BN" to "SX".

*Based on manufacturers rated recovery efficiency.

†Dimension to top of installed mixing device.

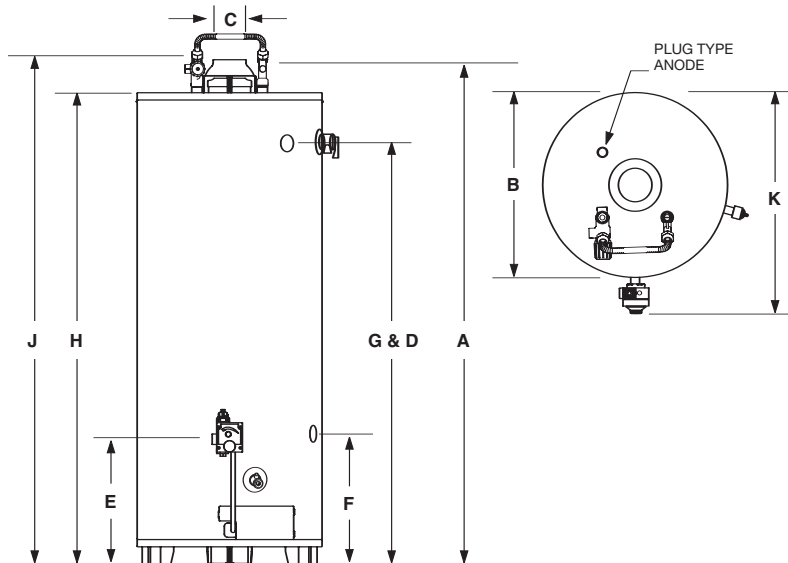

Integrated Mixing Device
(Installation required for operation)

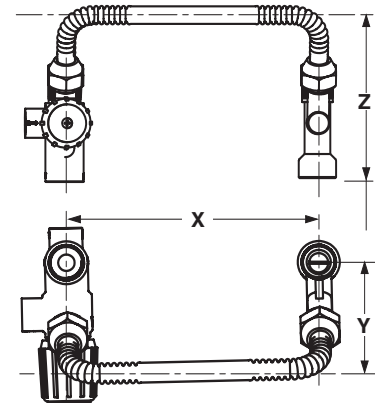

Model Number	X Distance Between Centers in.	Y Depth of Mixing Device in.	Z Height to Center of Pipe in.
GX-2-25S6BN	8	2½	6
GX-1-55S6BN	8	2½	6

General

All gas water heaters are certified at 300 PSI test pressure (2068 kPa) and 150 PSI working pressure (1034 kPa). All water connections are 3/4" NPT (19mm) on 8" (203mm) centers, all gas connections are 1/2" (13mm).

All models design certified by CSA International (formerly AGA/CGA), ANSI standard Z-21.10.3 and peak performance rated.

Dimensions and specifications subject to change without notice in accordance with our policy of continuous product improvement.

Suitable for Water (Potable) Heating and Space Heating.

Toxic chemicals, such as those used for boiler treatment, shall NEVER be introduced into this system. This unit may NEVER be connected to any existing heating system or component(s) previously used with a non-potable water heating appliance.



For U.S. and Canada field service, contact your professional installer or local Bradford White sales representative.

Sales 800-523-2931 • Fax 215-641-1670 / Technical Support 800-334-3393 • Fax 269-795-1089 • Warranty 800-531-2111 • Fax 269-795-1089

International: Telephone 215-641-9400 • Telefax 215-641-9750 / www.bradfordwhite.com

BRADFORD WHITE-CANADA INC. Sales / Technical Support 866-690-0961 / 905-238-0100 • Fax 905-238-0105 / www.bradfordwhite.com

Built to be the Best™

©2011, Bradford White Corporation. All rights reserved.